

Service Bulletin

Date: October 2003

Bulletin No: 27 002 03 (063)

BMW Motorrad USA

Subject: Wear of shock absorbing elements in rear belt drive, F 650 CS.

Details: The shock absorbing elements (number 6 in the illustration on page 2) in the hub of the rear belt drive will wear over time and require replacement.

Service Solution: The four (4) shock absorbing elements are to be replaced, together with the drive belt, every 24,000 miles.

A modified Maintenance Schedule for the F 650 CS is included on the 09/2003 edition TSD. The Maintenance Schedule identifies this added service item as:

**Replace toothed belt and damping elements *)
Every 40,000 km (24,000 miles)**

This service item is separate from regular maintenance and may be invoiced additionally using the information noted below.

Important Note: This part is a wear item and is not to be considered for replacement under the terms of the limited warranty unless there is evidence of a defect in material and/or workmanship. The Flat Rate Code and FRU information is provided for your Service Department's documentation and billing purposes.

Flat Rate Code: 27 72 550

Description: Replace toothed belt and reaction damping elements (associated work).

FUR: 16

Page two (2) of this bulletin is a supplement to the F 650 CS Repair Manual. This supplement contains a description of the additional steps involved in replacing the shock absorbing elements as parts of the procedure for changing the drive belt.

Contact: Pat Raymond
Service and Technical Manager
BMW Motorrad USA

(201) 307 4261
pat.raymond@bmwna.com

Operating Manager

Sales Department

Accessory Department

Parts Department

Service Department

Ref.: 27 56/2003



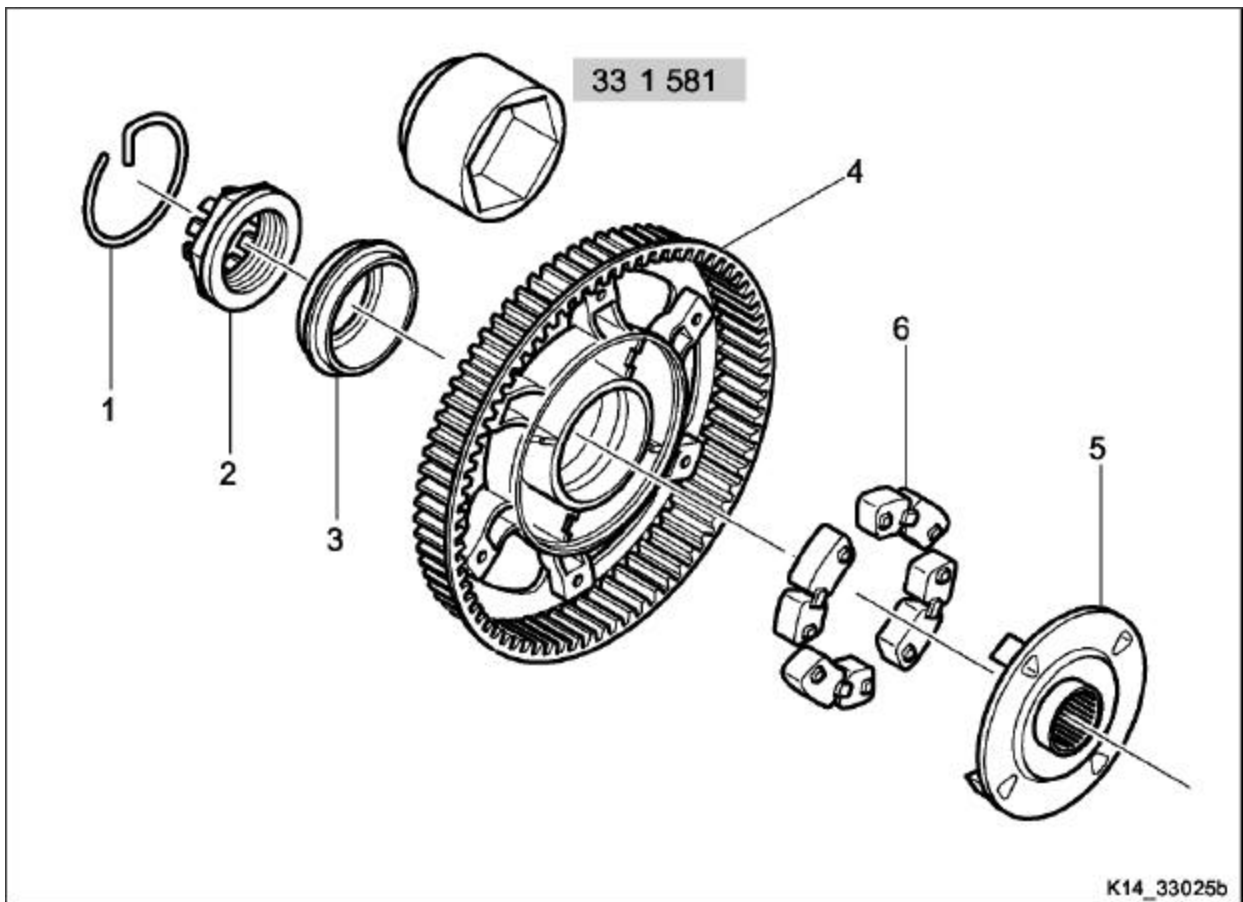

Removing and installing reaction damper

- Place the motorcycle on auxiliary stand, **BMW No. 00 1 620**.
- Belt tension relieved and eccentric pushed back.

Removing reaction damper

- Remove rear fastener of belt cover.
- Remove circlip (1).
- Depress the footbrake lever and remove nut (2) using socket wrench insert, **BMW No. 33 1 581**.
- Remove belt pulley (4) with the damper housing.
- Remove spacing bushing (3).

Replacing reaction-damping elements

- Remove driver (5).
- Remove reaction-damping elements (6).
- Clean driver (5) and the damper housing.
- Install new reaction-damping elements (6).
- Install driver (5).

Installing reaction damper

- Installation is the reverse of the removal procedure: pay particular attention to the following.
- Check the sealing ring and bearing in the damper housing for damage.
- Grease the splines of the input shaft with **Optimoly TA**.
- Apply **spray lubricant** to the splines in driver (5).

~ Tightening torque:

Threaded fastener of reaction damper160 Nm

- Replace the toothed belt, if necessary (Rep 00.54).
- Adjust the tension of the drive belt (Rep 00.56).