

# Mounting Instructions

BM 048 – BMW F 650 GS

## Kit contents

Shock absorber 46 HRCS	BM 048	
Tie rap	00231-01	2
Sticker Öhlins	00192-01	2
Memo sticker	01180-01	1
Owners manual		1

## Set-up data

Lenght	328.5 mm
Stroke	60.5 mm
Rebound adjustment	14 clicks
Compression adjustment	12 clicks
Spring Preload	15 mm



ADVANCED SUSPENSION TECHNOLOGY

Öhlins Racing AB, Box 722, S-194 27 Upplands Väsby, Sweden.

E-mail: [info@ohlins.se](mailto:info@ohlins.se)

Web: [www.ohlins.com](http://www.ohlins.com)

BM 048, Issued 00 12 13



ADVANCED SUSPENSION TECHNOLOGY

## Safety signals

Important information concerning safety is distinguished in this manual by the following notations.



The Safety alert symbol means:  
Caution! Your safety is involved.

### WARNING!

Failure to follow warnings could result in **severe or fatal injury** to anyone working with, inspecting or using the suspension, or to bystanders.

### CAUTION!

Caution indicates that special precautions must be taken to avoid damage to the suspension.

### NOTE!

This indicates information that is of importance with regard to procedures.

### Kit contents

Before installing the shock absorber, please check the contents of the kit, listed on the front page of this instruction. If anything is missing, contact your Ohlins dealer.

### NOTE!

During storage and transportation, especially at high ambient temperature, the oil and grease used for assembling may run out in-side the packing and damage the expanded polystyrene packing material. This is not unusual and is in no way detrimental to the shock absorber.

© Ohlins Racing AB.  
All rights reserved.  
Any reprinting or unauthorized use without the written permission of Ohlins Racing AB is prohibited.  
Printed in Sweden.

## Before you start

### WARNING!

Installing a shock absorber, that is not approved by the vehicle manufacturer, may affect the stability of your vehicle. Ohlins Racing AB cannot be held responsible for any personal injury or damage whatsoever that may occur after fitting the shock absorber. Contact an Ohlins dealer or other qualified person for advice.

Ohlins Racing AB can not be held responsible for any damage whatsoever to shock absorber or vehicle, or injury to persons, if the instructions for fitting and maintenance are not followed exactly. Similarly, the warranty will become null and void if the instructions are not adhered to.

### WARNING!

Please study and make certain that you fully understand all the mounting instructions and the owner's manuals before handling this shock absorber kit. If you have any questions regarding proper installation procedures, contact an Ohlins dealer or other qualified person.

### WARNING!

The vehicle service manual must be referred to when installing the Ohlins shock absorber.

### NOTE!

Ohlins products are subject to continual improvement and development. Consequently, although these instructions include the most up-to-date information available at the time of printing, there may be minor differences between your suspension and this manual. Please consult your Ohlins dealer if you have any questions with regard to the contents of the manual.

## Notes



6

Remove the control box and all electric connections (4 pcs) and let the loose wiring hang out to the right side of the motorcycle.

**CAUTION!**

When removing the fuel tank it must be emptied or contain very small amounts of fuel. Otherwise it will flow over when the fuel lines are loosened.

7

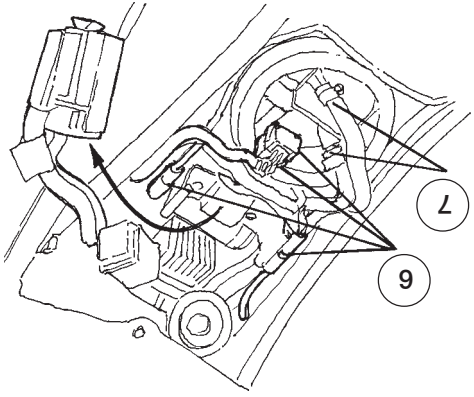

Loosen the two fuel lines.

8

Loosen the four bolts holding the rear subframe unit.

9

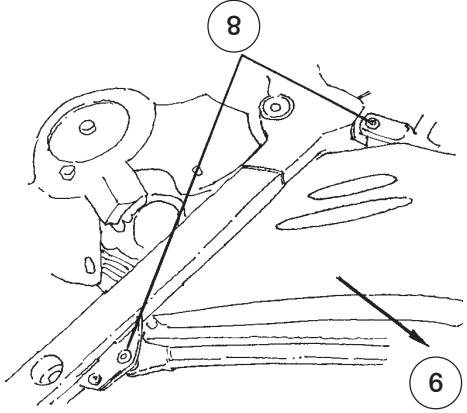

Lift the rear unit backwards, upwards and remove it from the motorcycle.

9

10

Remove the original reservoir by loosening the two o-rings of the bracket.

11

Loosen and remove the original hydraulic pre-load adjuster and the bracket.

12

Loosen the lower bracket of the right droplink and pull it backwards, so the lower shock absorber mount is reachable.

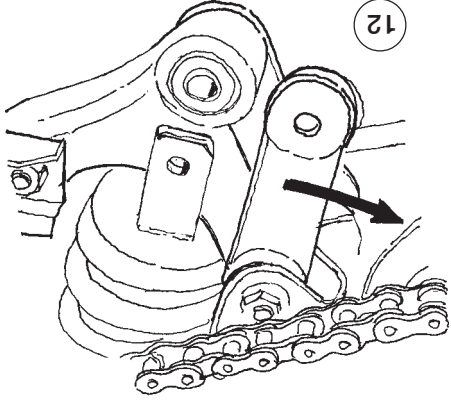

8

13

Loosen the lower shock absorber mounting bolt to release the shock absorber from the triangle link.

14

Loosen the upper shock absorber mounting bolt and remove the shock absorber by lifting it upwards.

15

Fit the Ohlins shock absorber in reverse order. First fit the lower shock absorber mounting bolt.

15

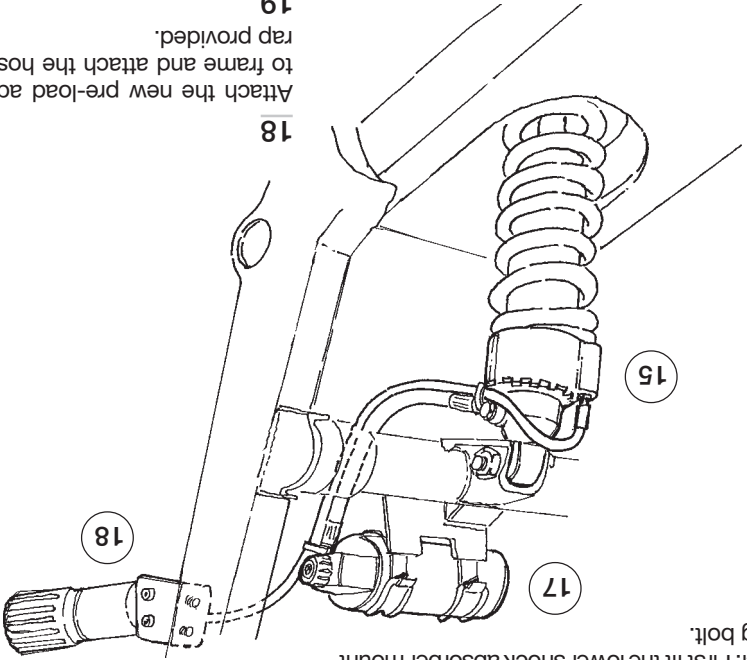

16

Then fit the upper shock absorber mounting bolt and tighten. Bring the droplink back in position again and fit the pivot bolt and nut.

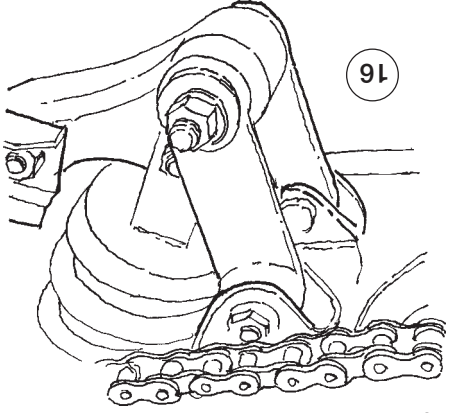

17

Fit the reservoir in the original bracket. Pull the hose under the upper shock absorber bracket.

23

Continue your work according to Owners manual.

**NOTE!**

Make sure that all bolts are tightened to the correct torque and that nothing fouls or restricts movement of the shock absorber when the suspension is being fully compressed or extended.

22

Put the seat back in position and lock it. Close the toolbox lid.

21

Refit first the left and then the right silencer.

20

Refit the fuel tank and fix the bolts. Refit the fuel lines and the electrical connections. Refit the control box.

19

Attach the new pre-load adjuster bracket to frame and attach the hose with the tie-  
rap provided.